

# Fun with Art & Activity

-: Concept and Visualisation :-

Ekta Arora  
Saloni



NAME

CLASS

SCHOOL

# INDEX

S N.	Contents	Pages
1.	Facial Expressions	3
2.	Project Work	4
3.	Elephant	5
4.	A Cock	6
5..	Spray painting	7
6.	Onion Printing	8
7.	Paper Folding	9
8.	Vegetable Impression	10
9.	Valentine Heart Wreath	11
10.	Decorate With Buttons	12
11.	Cup	13
12.	Landscape	14
13.	Landscape	15
14.	Colour the Swan	16
15.	Pencil Shading	17
16.	Oil pastel Colours	18
17.	Paper Collage	19
18.	Fish	20
19.	Greeting Card	21
20.	Ladyfinger Impression	22

S N.	Contents	Pages
21.	Activity	23
22.	Yarn Wrapped Cardinal	24
23.	Triangular Design	25
24.	Shaded Landscape	26
25.	Shaded Landscape	27
26.	Oil pastel Colours / Thumb Impression	28
28.	Rainbow	29
29.	Activity / Block Painting	30
30.	Butterfly with Origami	31
31	Brinjal	32



# Facial Expressions

Observe the facial expressions and sketch them in the blank faces.



## Let Me Answer

- \* What kind of facial expressions do you make when you are happy?
- \* Do you make sad face when your friend get upset with you?

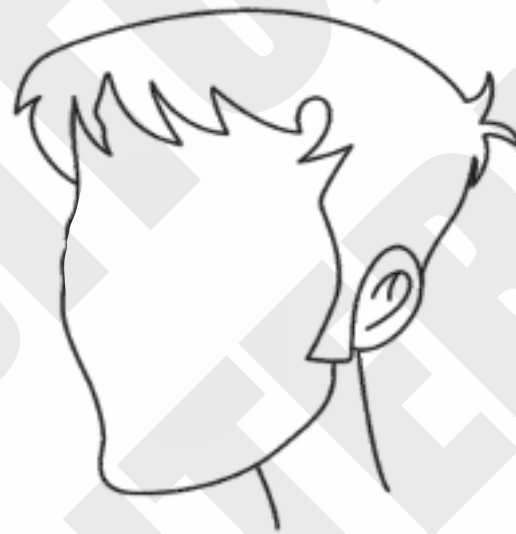
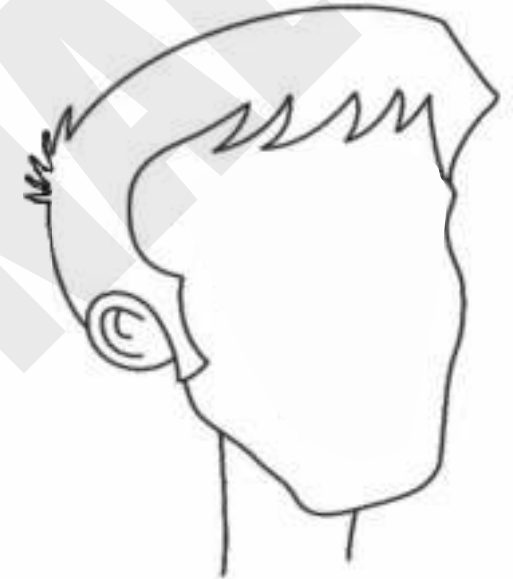

Excellent		A	Good		B	Fair		C
		<input type="checkbox"/>			<input type="checkbox"/>			<input type="checkbox"/>

Teacher's Remark

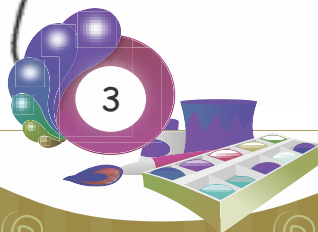



# Project Work

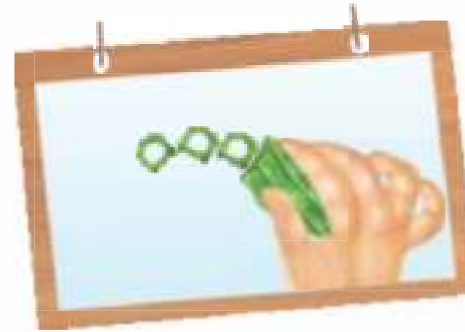
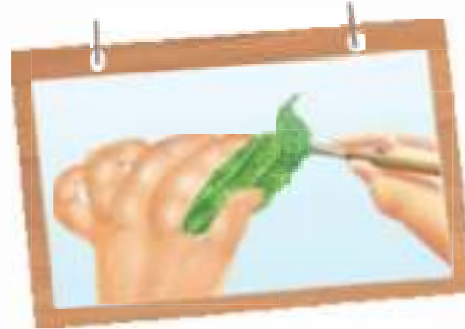
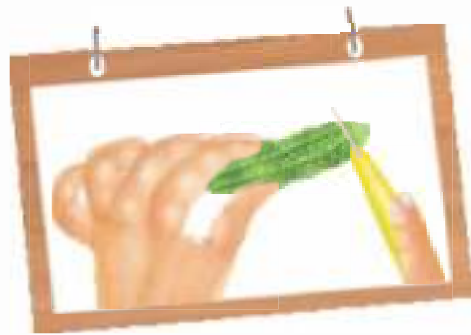

## Materials Required:

- Bittergourd
- Green colour
- Painting brush
- Tree branches or twigs

## Steps:

Take a bittergourd and cut half for making leaves with the help of a thick brush. Put some green colour on the cuts of bittergourd. Then put impression on the white pastel space provided on the next page to make leaves. Paste the tree branches or twigs as shown in reference.



## Let Me Answer

- \* Which vitamin is found in bitter gourd?
- \* What is the another name of bitter gourd?



# Elephant



## Let Me Answer

- \* Where can you find elephants?
- \* How much an average do they need to eat to survive?

Let's learn how to make the picture of an elephant step by step. Colour it with water colour.

STEP-1

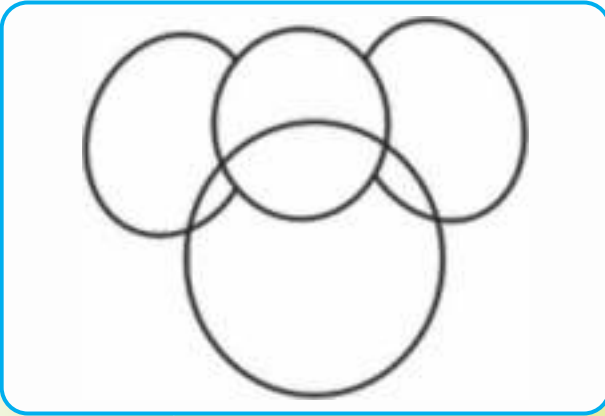

STEP-2



STEP-3

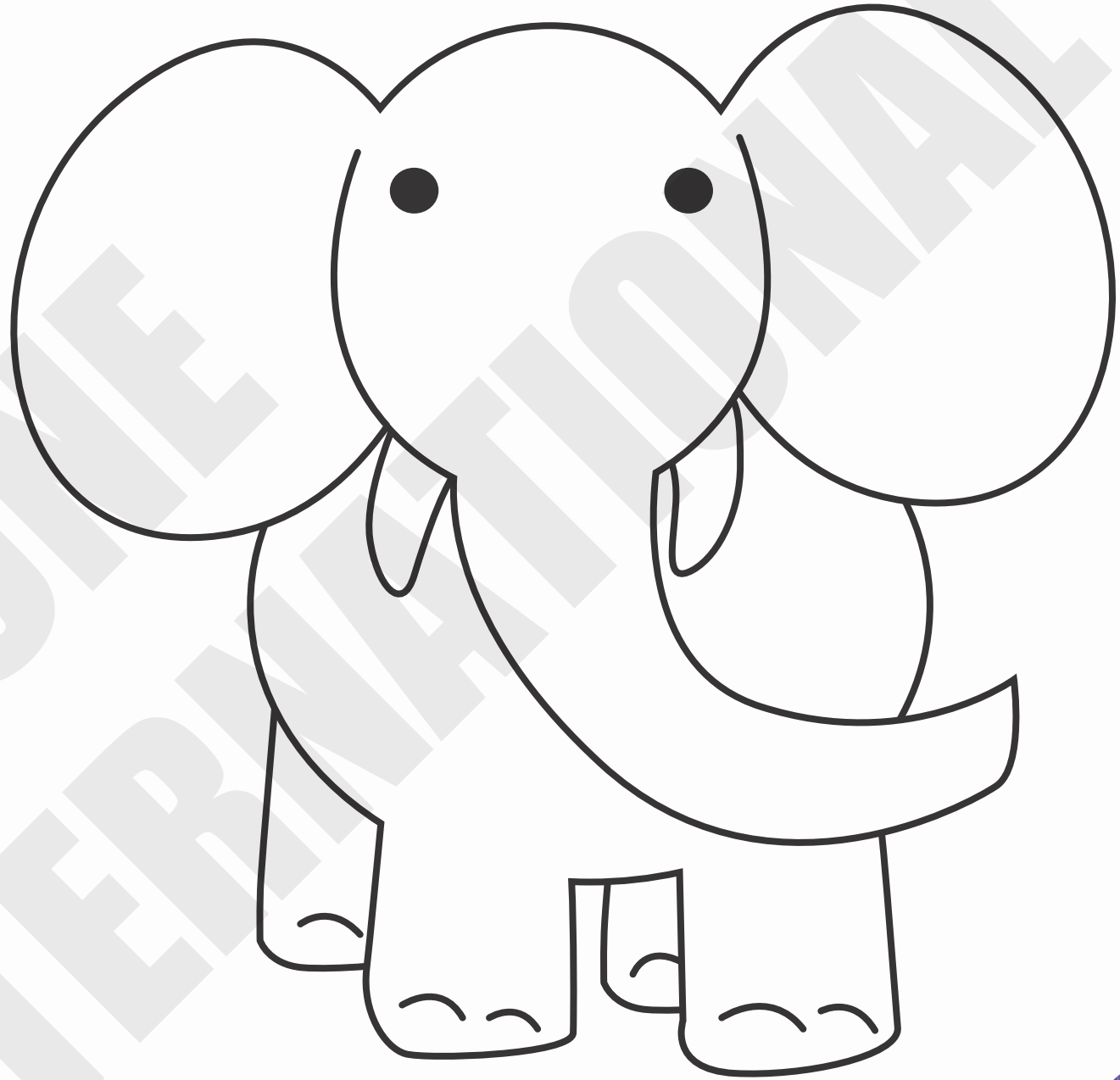
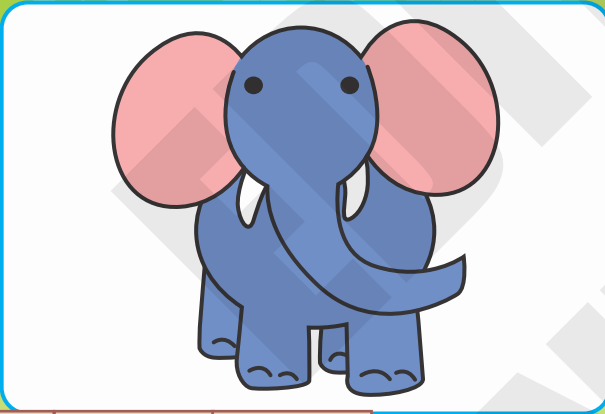

Excellent  A  Good  B  Fair  C

Teacher's Remark



# A Cock

The cock is saying that the sun is about to rise. Wake up dear children to become healthy, wealthy and wise. Brighten up the scene with the colours of your choice.



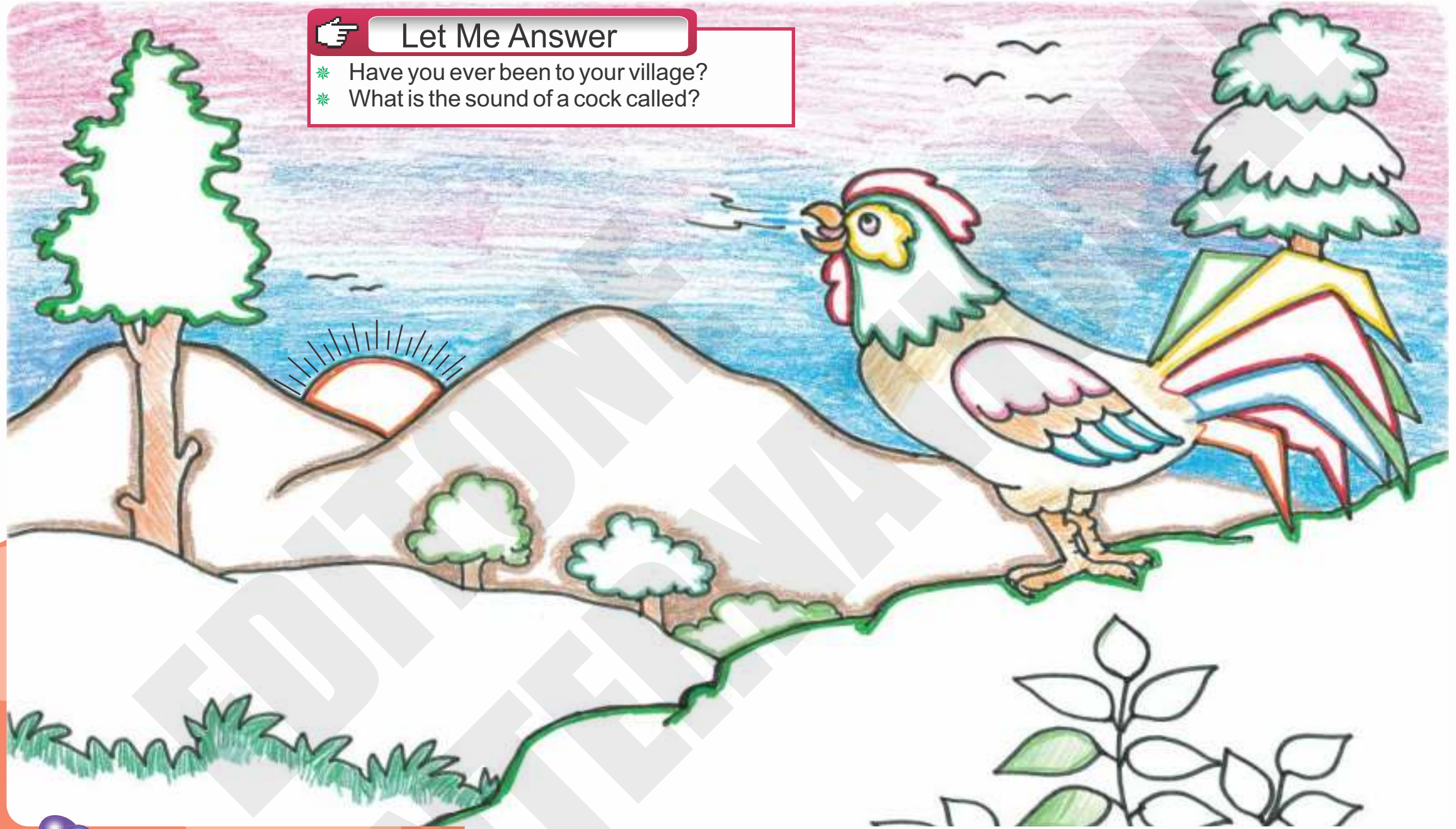

## Let Me Answer

- \* Have you ever been to your village?
- \* What is the sound of a cock called?



Teacher's Remark

Excellent 	A <input type="checkbox"/>	Good 	B <input type="checkbox"/>	Fair 	C <input type="checkbox"/>
---	----------------------------	--	----------------------------	--	----------------------------





## Spray Painting

Look at the coloured picture created by tooth brush spray technique. Recreate the same in the given outline.

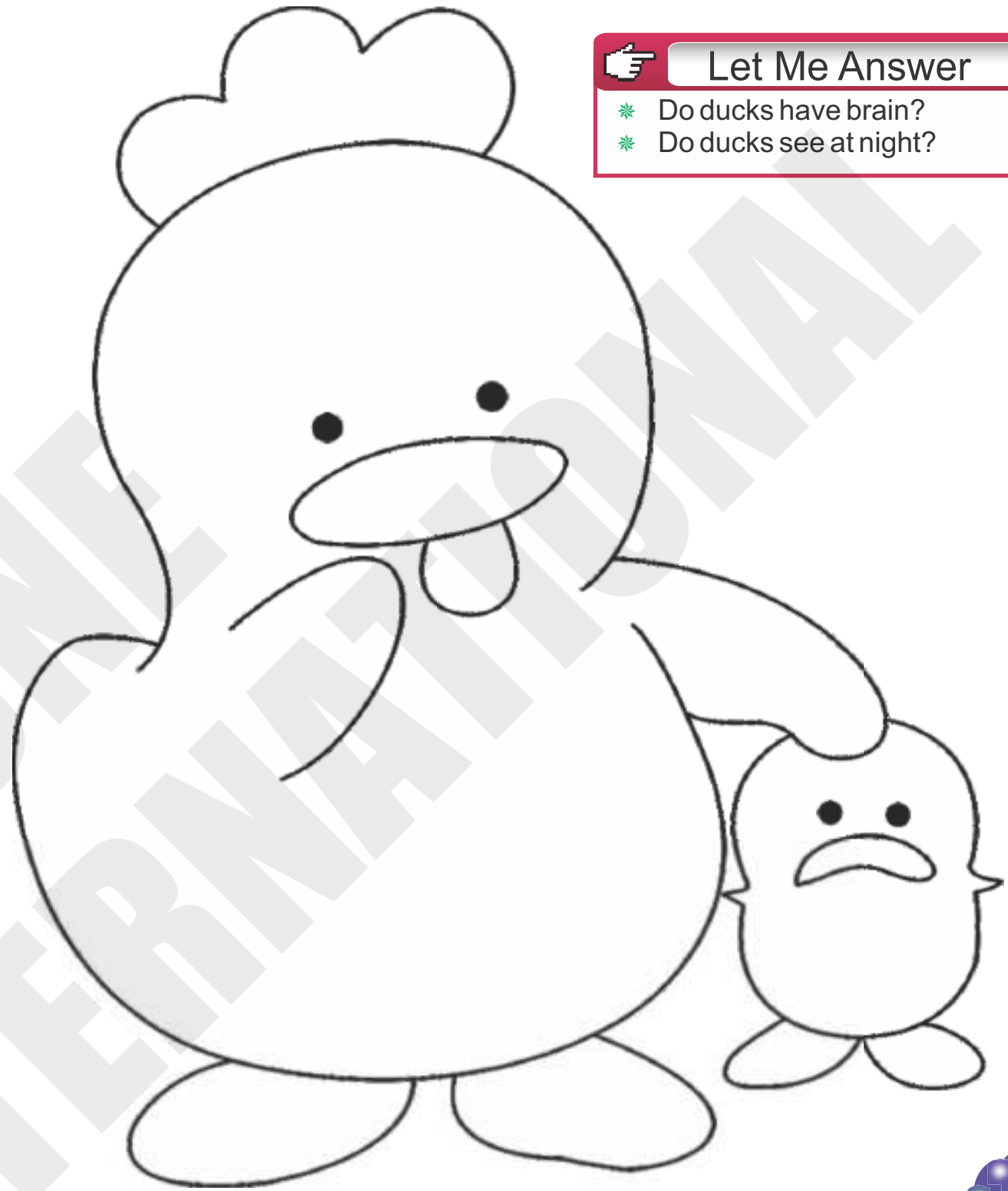

### Let Me Answer

- \* Do ducks have brain?
- \* Do ducks see at night?

Excellent	<input type="checkbox"/>	A	Good	<input type="checkbox"/>	B	Fair	<input type="checkbox"/>	C
-----------	--------------------------	---	------	--------------------------	---	------	--------------------------	---

Teacher's Remark

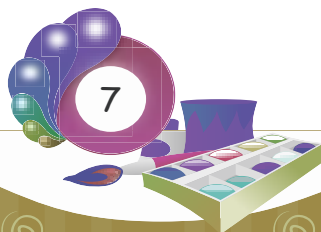



# Onion Printing

Make a beautiful Rangoli design, using onion printing art with the help of different colours.

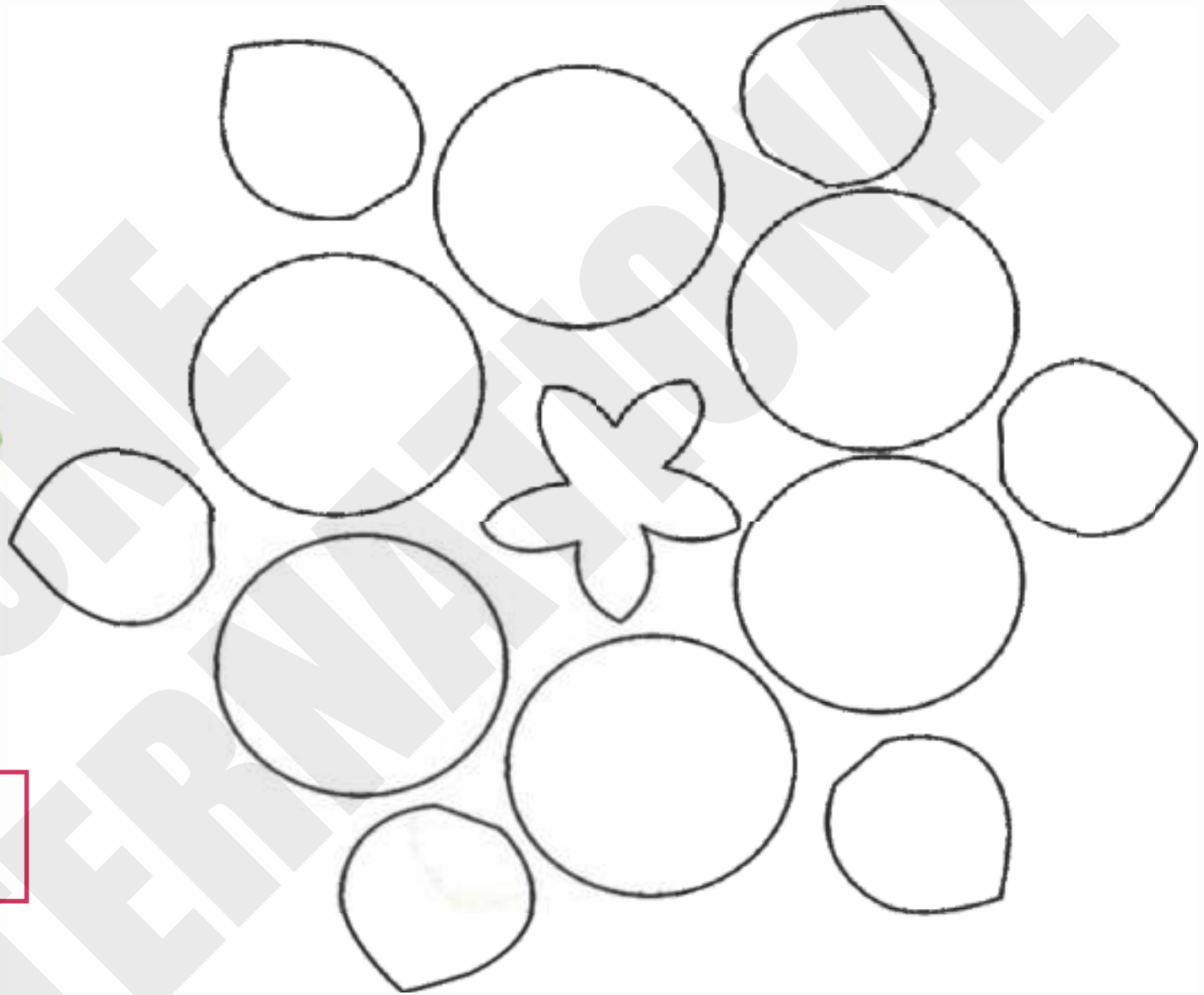

## Let Me Answer

- \* In which month onion crop is grown.
- \* Which part of onion is used as food?



# Paper Folding

Follow the steps to make an origami LADYBUG.

**1** Start with a square piece of paper, white side up. Fold in half.

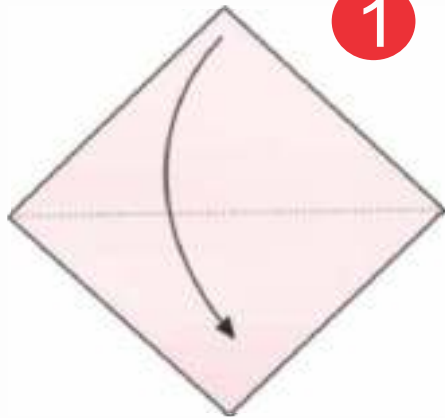

**2** Fold this triangle in half, crease well then open.

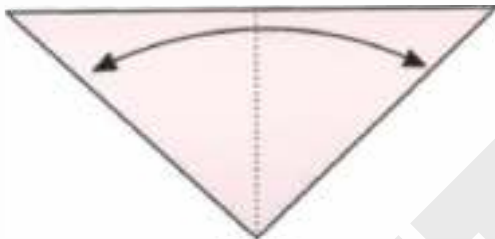

**3** Fold the top 2 corners downwards, but not right to the center line: leave a little gap.

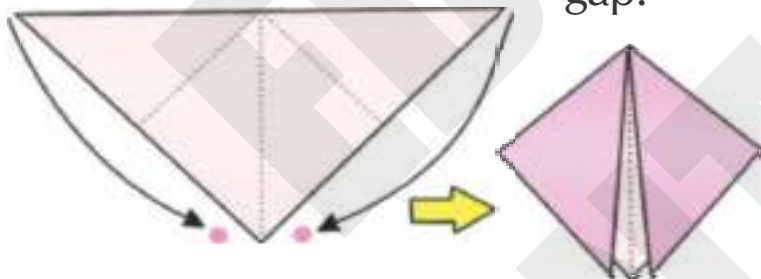

## Let Me Answer

- \* What does ladybug eat?
- \* What kind of animal is a ladybug?

**4** Turn model over. Fold down top corner to the center point of the model.

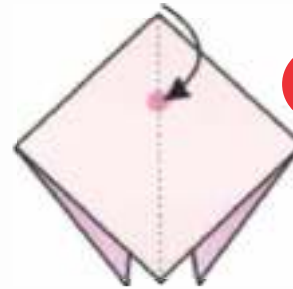

**5** Now fold this corner upwards, and flatten.



**6** Turn back over. Finished Ladybug.



Excellent	A	Good	B	Fair	C	Teacher's Remark
<input type="checkbox"/>	<input type="checkbox"/>	<input type="checkbox"/>	<input type="checkbox"/>	<input type="checkbox"/>	<input type="checkbox"/>	



# Vegetable Impression

## Steps to follow:

1. Take an onion and cut into halves.
2. Dip the halves of onion into water colour to put impression on the space provided to make flowers.
3. Similarly, use the full circles of onion to complete the flower.
4. Colour rest of the picture as indicated.

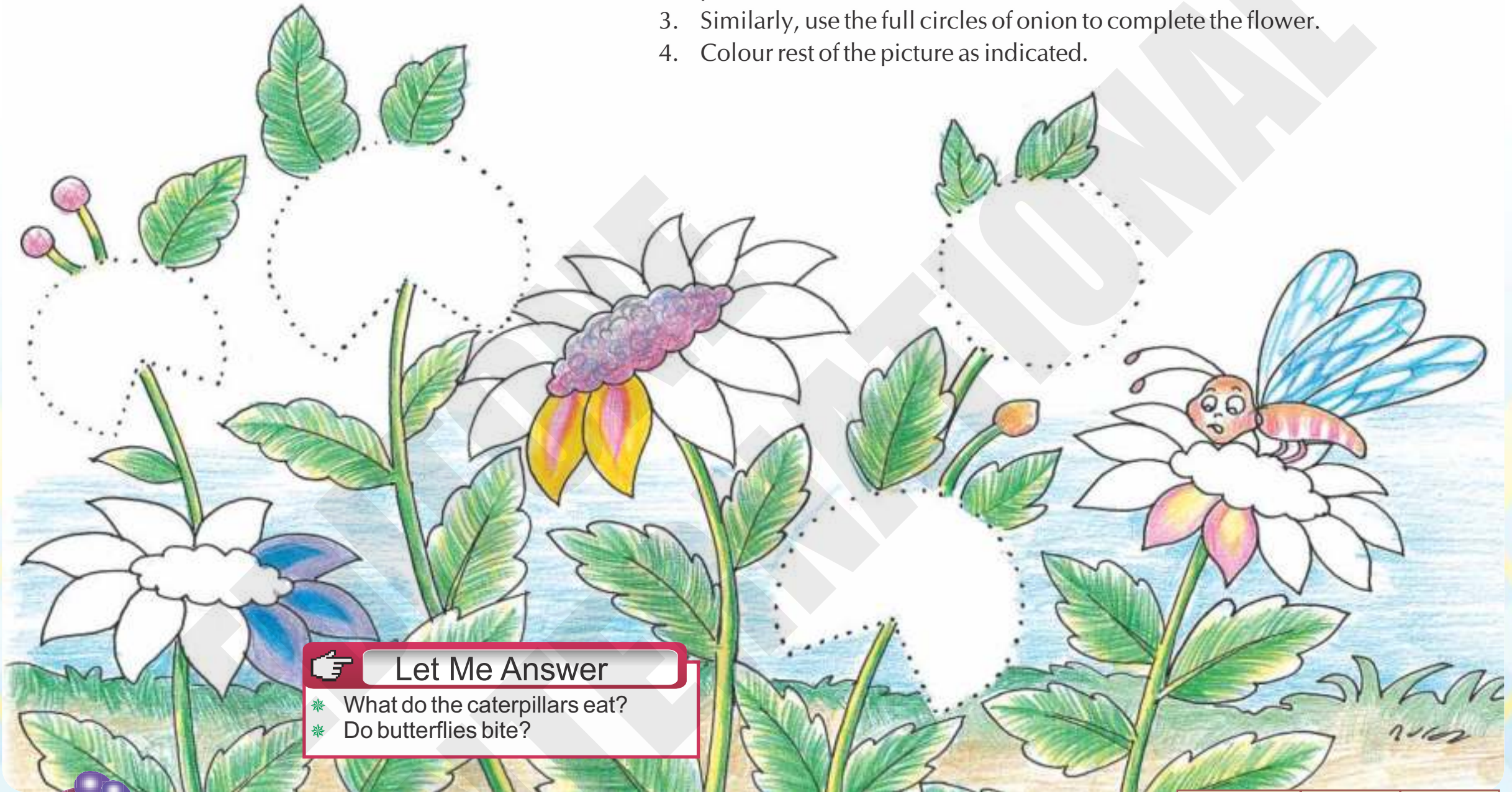

 **Let Me Answer**

- \* What do the caterpillars eat?
- \* Do butterflies bite?

Teacher's Remark

Excellent 	A <input type="checkbox"/>	Good 	B <input type="checkbox"/>	Fair 	C <input type="checkbox"/>
---	----------------------------	--	----------------------------	--	----------------------------





# Valentine Heart Wreath (Project Work)

## You will need:

1. Red and pink construction paper.
2. A paper plate
3. Scissors
4. Glue
5. Optional-glitter

## Steps:



1. Cut a large hole in the paper plate.
2. Cut out a lot of hearts from red and pink paper.
3. Glue the hearts to the paper plate.
4. Optional: Decorate the hearts with the names of the children. Also glitter is a nice touch.



 **Let Me Answer**

- \* Do you know the shape of a heart?
- \* How many heart shapes are there on the paper plate?



Excellent 	A <input type="checkbox"/>	Good 	B <input type="checkbox"/>	Fair 	C <input type="checkbox"/>
---	----------------------------	--	----------------------------	--	----------------------------

Teacher's Remark





## Decorate With Buttons

Here buttons are looking like flowers. It is very simple work in face. Circles Just Collect some old buttons from the waste clothes or ask your parent for them. Apply glue first on the where you want to stick the buttons, then place the buttons one after the other so that the whole arrangement look beautiful.

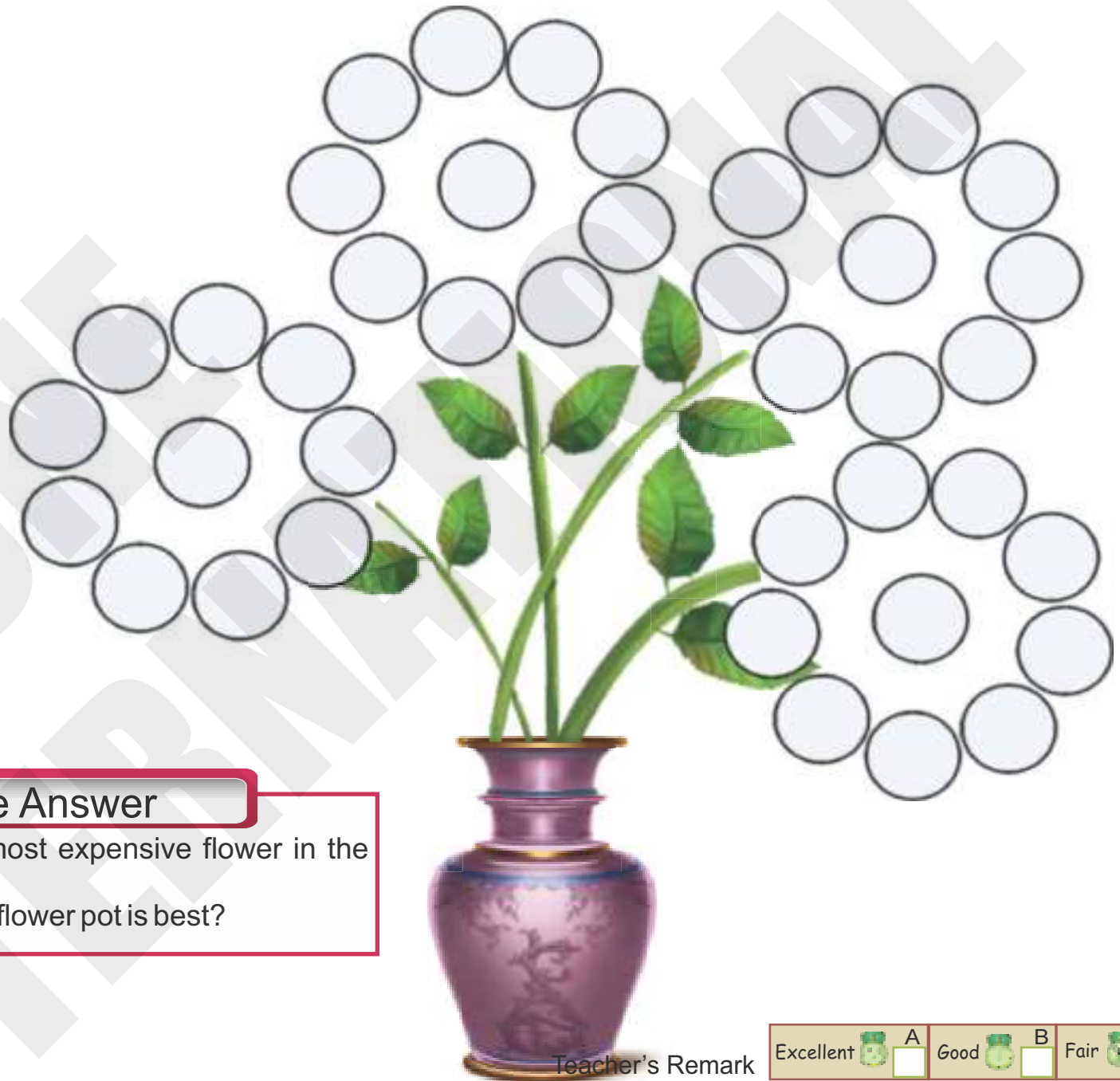
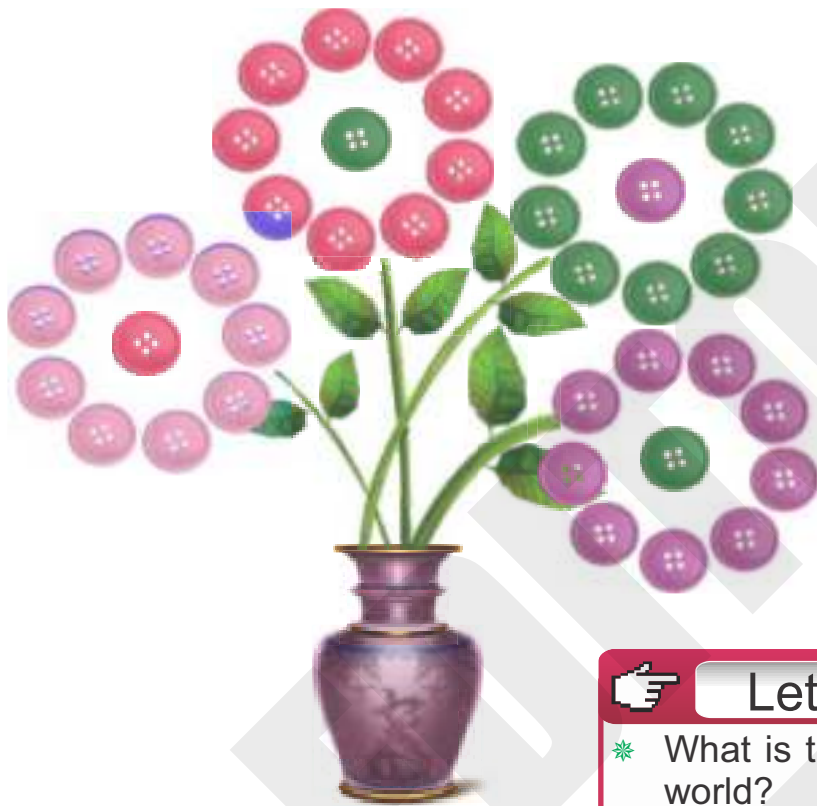

### Let Me Answer

- \* What is the most expensive flower in the world?
- \* Which type of flower pot is best?

Teacher's Remark

Excellent		A	Good		B	Fair		C
	<input type="checkbox"/>		<input type="checkbox"/>	<input type="checkbox"/>		<input type="checkbox"/>		





# Cup

Complete the picture by joining the number 1-70. Also colour the cup and saucer with attractive colours. Now you can hold your cup.

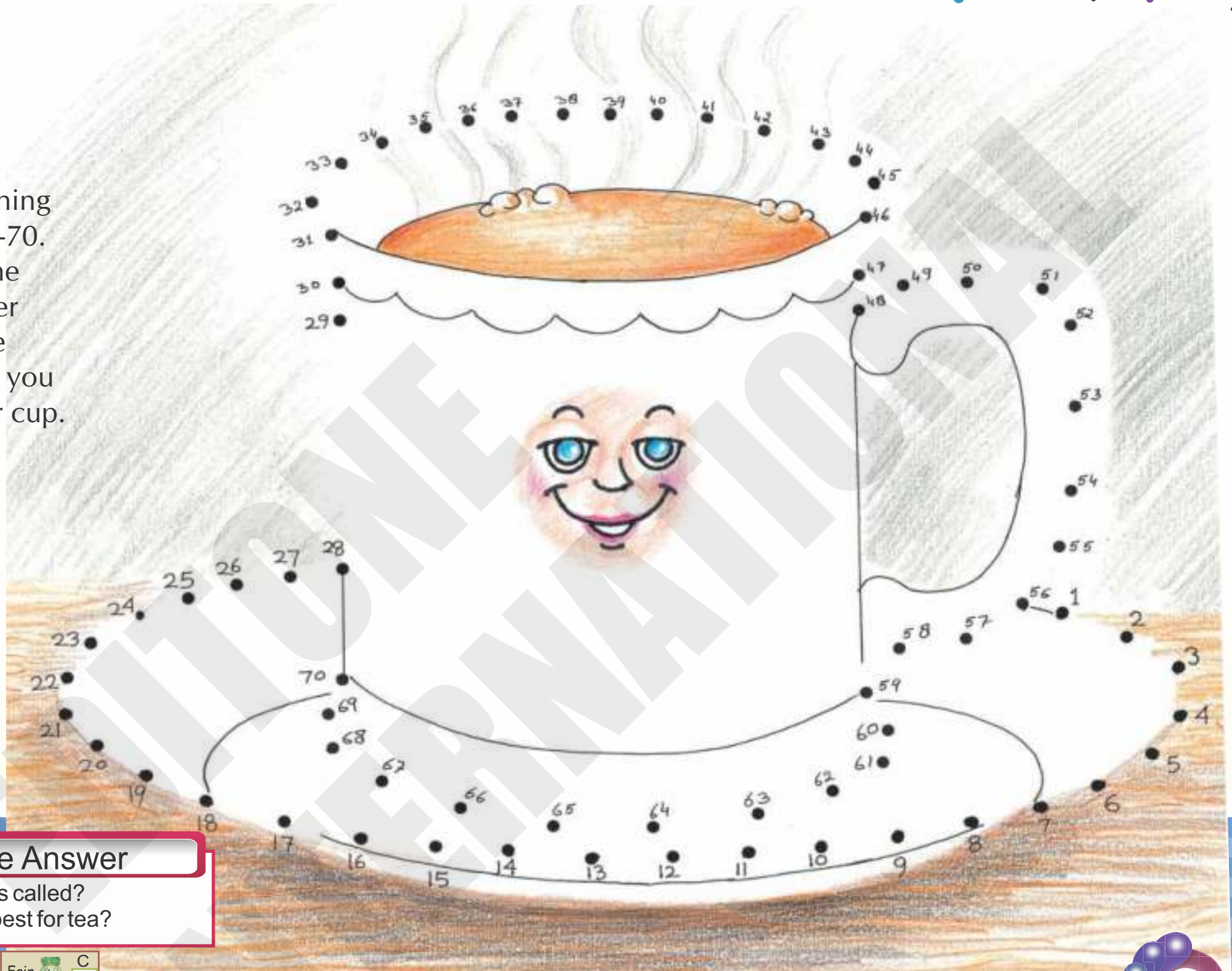

## Let Me Answer

- \* What are cups called?
- \* which cup is best for tea?

Excellent  A  Good  B  Fair  C

Teacher's Remark

Part-4

13





# Landscape

Draw a landscape on the next page using a sharp pencil and shade it with oil pastel colours.



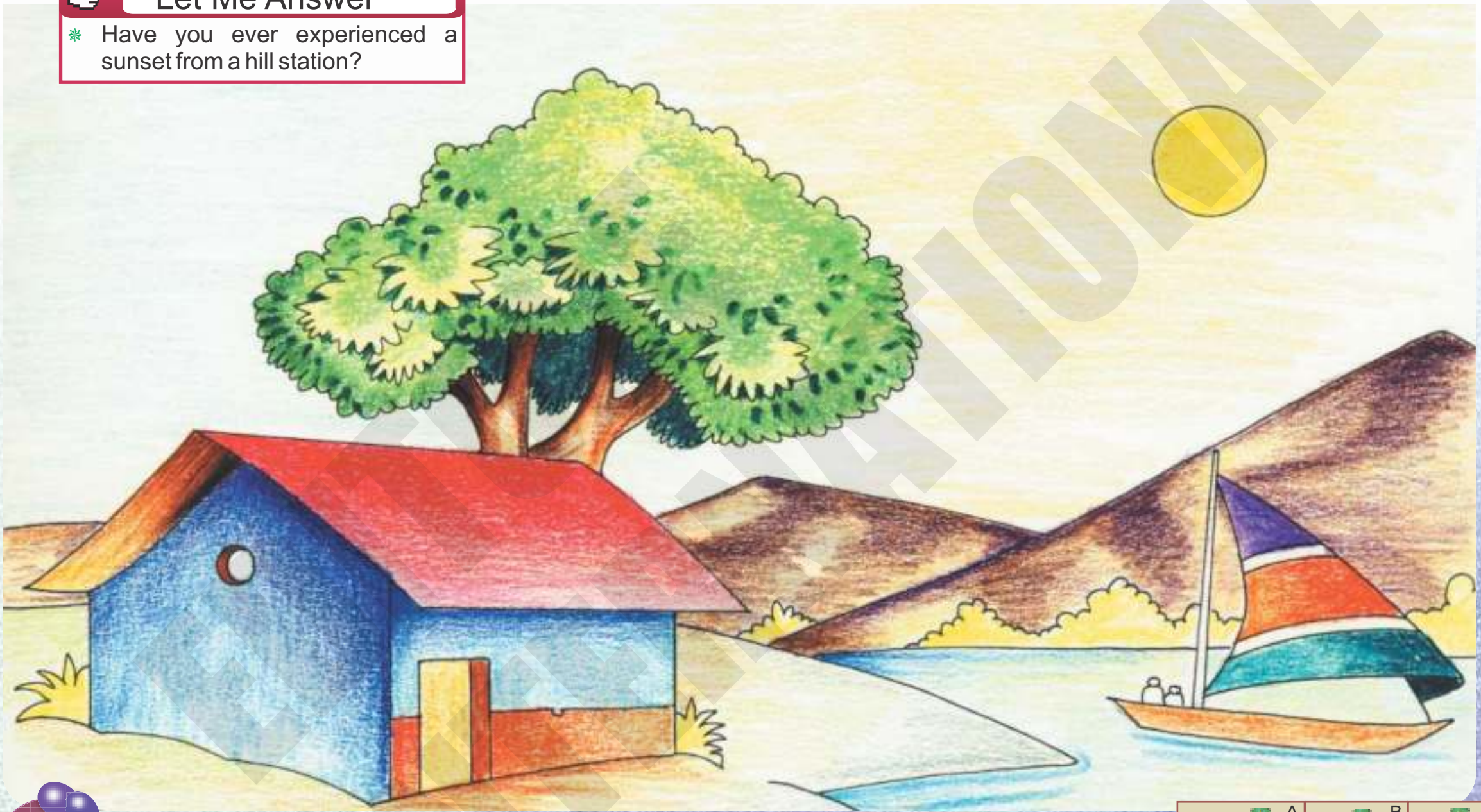

## Let Me Answer

\* Have you ever experienced a sunset from a hill station?



Teacher's Remark

Excellent 	A <input type="checkbox"/>	Good 	B <input type="checkbox"/>	Fair 	C <input type="checkbox"/>
---	----------------------------	--	----------------------------	--	----------------------------



Draw a landscape as per the reference shown on previous page.



### Let Me Answer

\* How many consonants and vowels are there in the word landscape.

EDITION INTERNATIONAL

Excellent		A	<input type="checkbox"/>	Good		B	<input type="checkbox"/>	Fair		C	<input type="checkbox"/>
-----------	--	---	--------------------------	------	--	---	--------------------------	------	--	---	--------------------------

Teacher's Remark





# Colour the Swan

Look at this beautiful swan painted in pastel colours. Colour it using light and dark tones of colours (apply dark tones first.)



## Let Me Answer

- \* Where do swans sleep at night?
- \* What do swans eat?

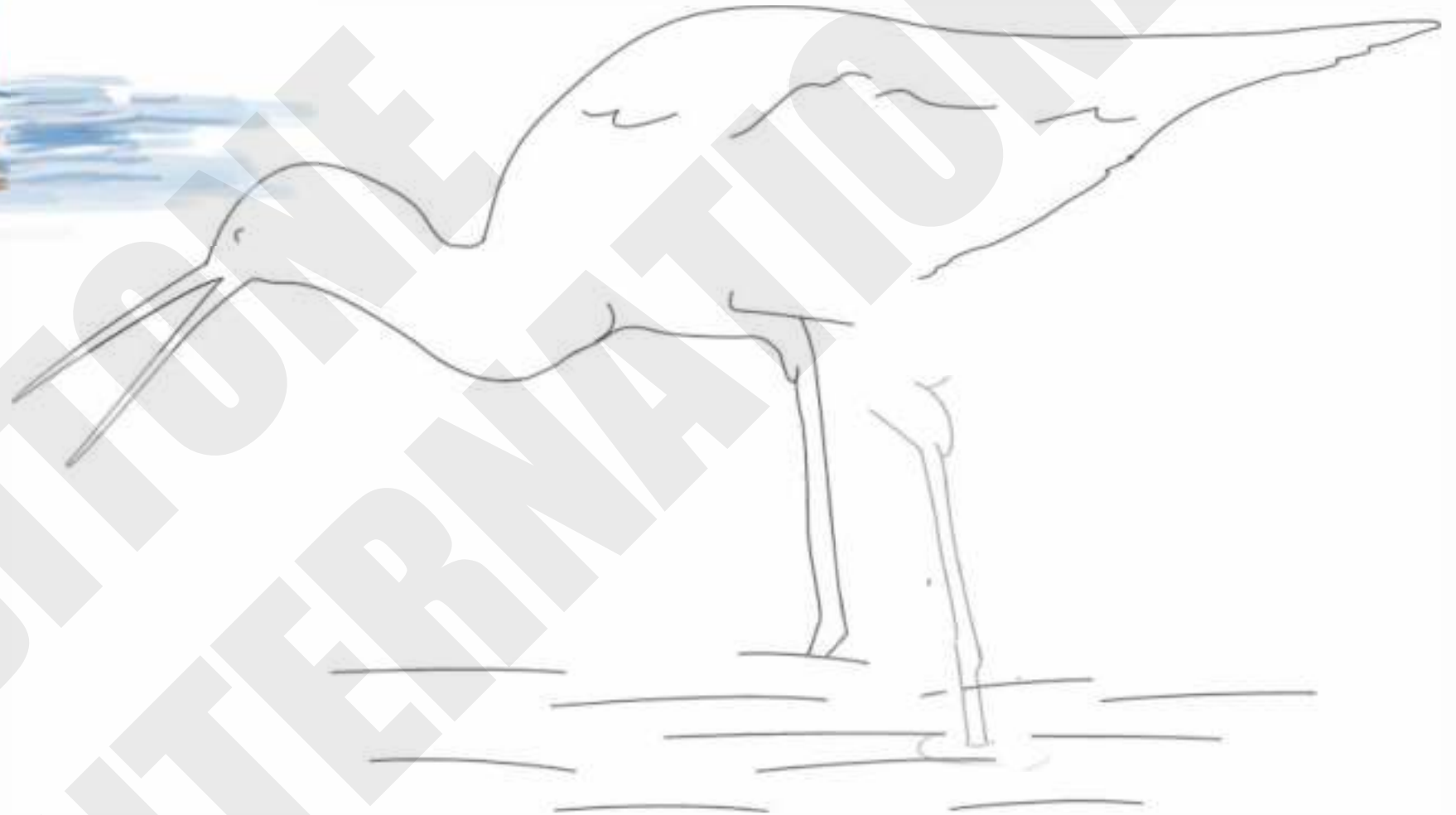

Teacher's Remark

Excellent 	A <input type="checkbox"/>	Good 	B <input type="checkbox"/>	Fair 	C <input type="checkbox"/>
---	----------------------------	--	----------------------------	--	----------------------------





## Pencil Shading

See how beautiful this picture is ! Draw a similar picture as shown in the space provided. Use only pencil to draw the picture and apply shading.



### Let Me Answer

\* Have you ever heard the sound of ektara?



Excellent  A  Good  B  Fair  C

Teacher's Remark





# Oil Pastel Colours

Diwali is the festival of lights, crackers and sweets.

Complete this beautiful Diwali picture with the colours of your choice.

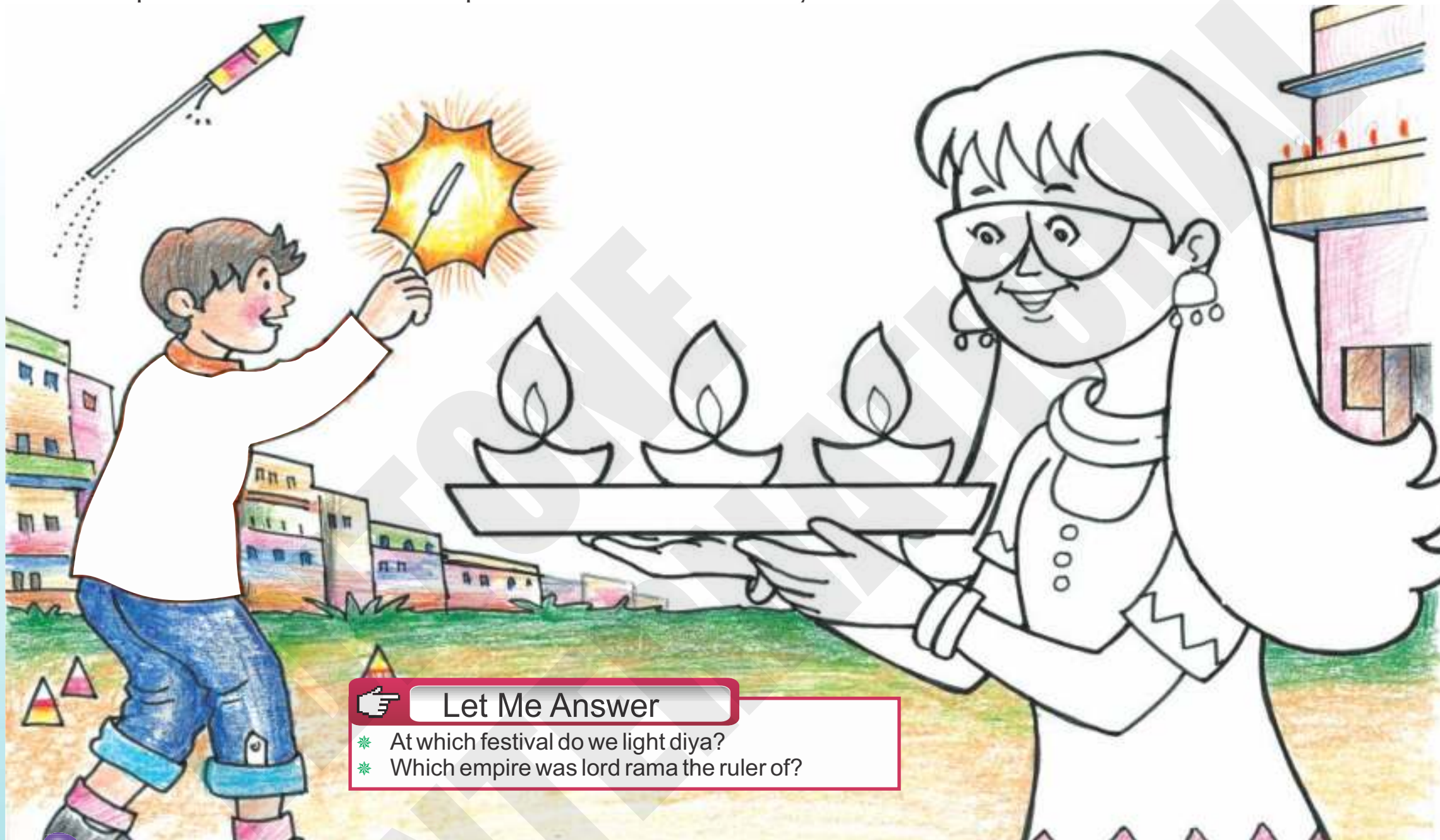

## Let Me Answer

- \* At which festival do we light diya?
- \* Which empire was lord rama the ruler of?



# Paper Collage

Tear and paste different coloured papers in the shapes given in this space provided and paste them to make this beautiful scene.



## Let Me Answer

- \* In which region coconut trees are found?
- \* Which fruit is popular in south India?

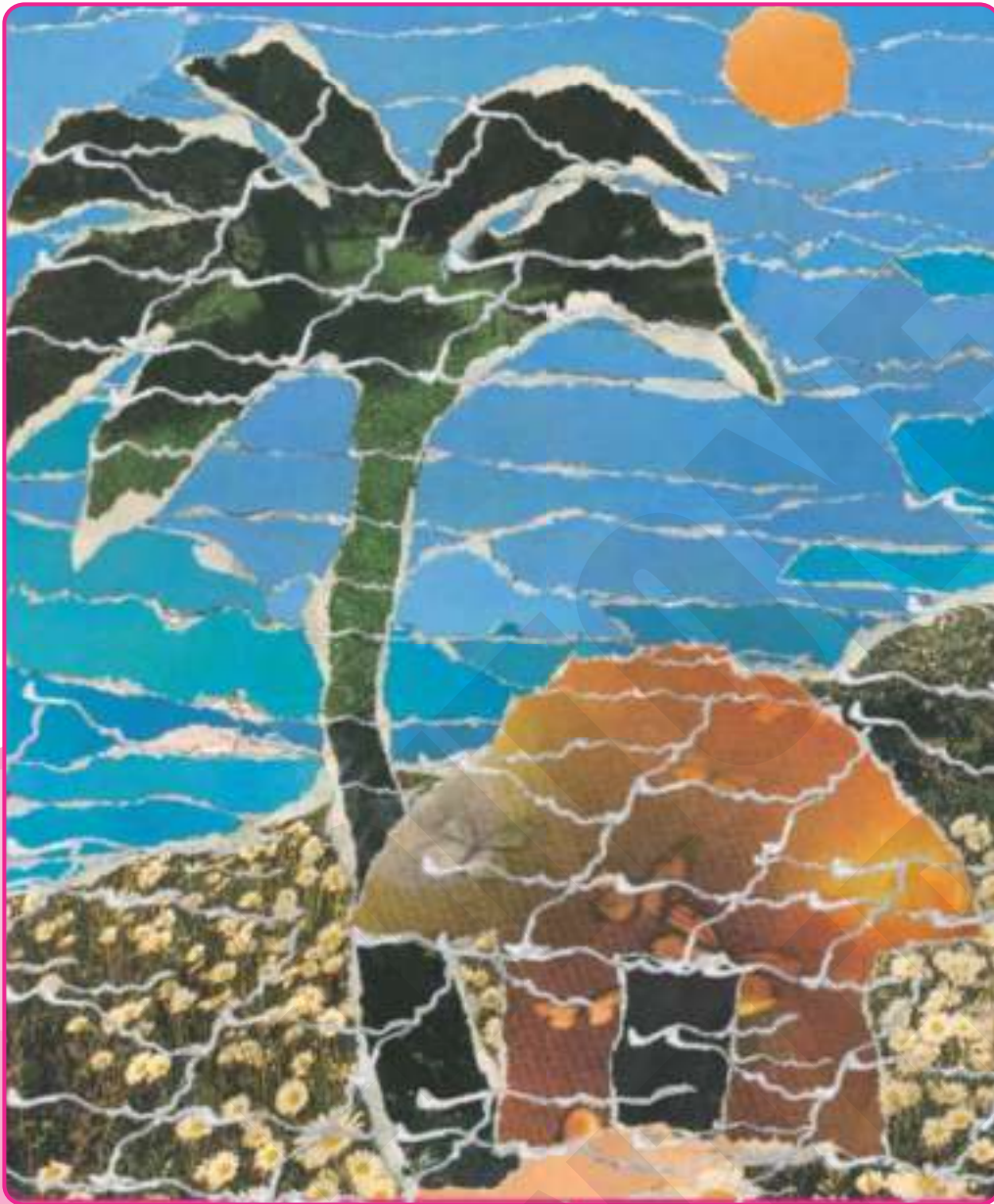

Excellent	<input type="checkbox"/>	A	Good	<input type="checkbox"/>	B	Fair	<input type="checkbox"/>	C
-----------	--------------------------	---	------	--------------------------	---	------	--------------------------	---

Teacher's Remark





# Fish

Draw the given pattern using sketch pens as shown in the reference.



## Let Me Answer

- \* Which is the largest fish in the world?
- \* How do fish breathe in the water?





## Greeting Card

Look at the greeting card shown below. Now draw the same in the box given on the right. Also shade it with colour pencils to make it beautiful. You can also write your own messages on it.



### Let Me Answer

- \* Have you ever made a greeting card for your mother?
- \* Who invented greeting cards?

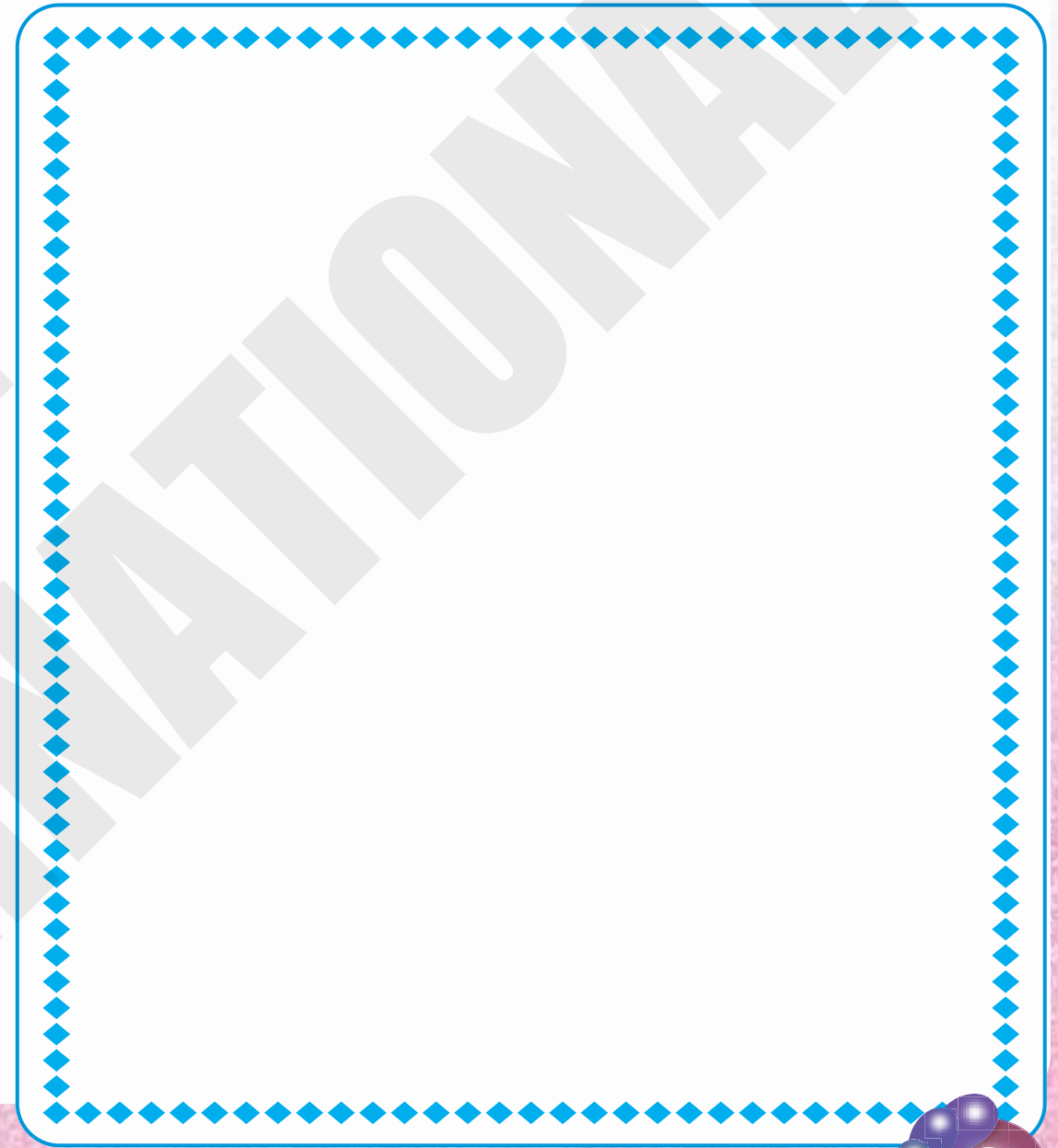

Excellent  A  Good  B  Fair  C

Teacher's Remark

Part-4

21





# Ladyfinger Impression

Make beautiful flowers by using ladyfinger impressions as given in the reference.



## Let Me Answer

\* In what season does a lady finger grow?

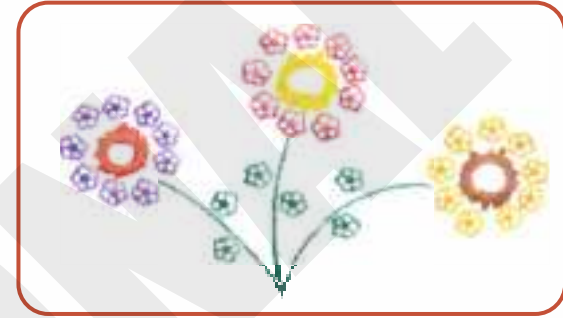



Take a separate drawing sheet, trace the outline, ask your parents / teacher to make a cutout and stencil with the help of a cutter. Now fix the stencil and the cutout on the given spaces. Put colours in a palette, dip the toothbrush in it and spray the colour one by one on stencil and cutout. For more depth in colour wash the toothbrush and dip it into the other colour and spray.

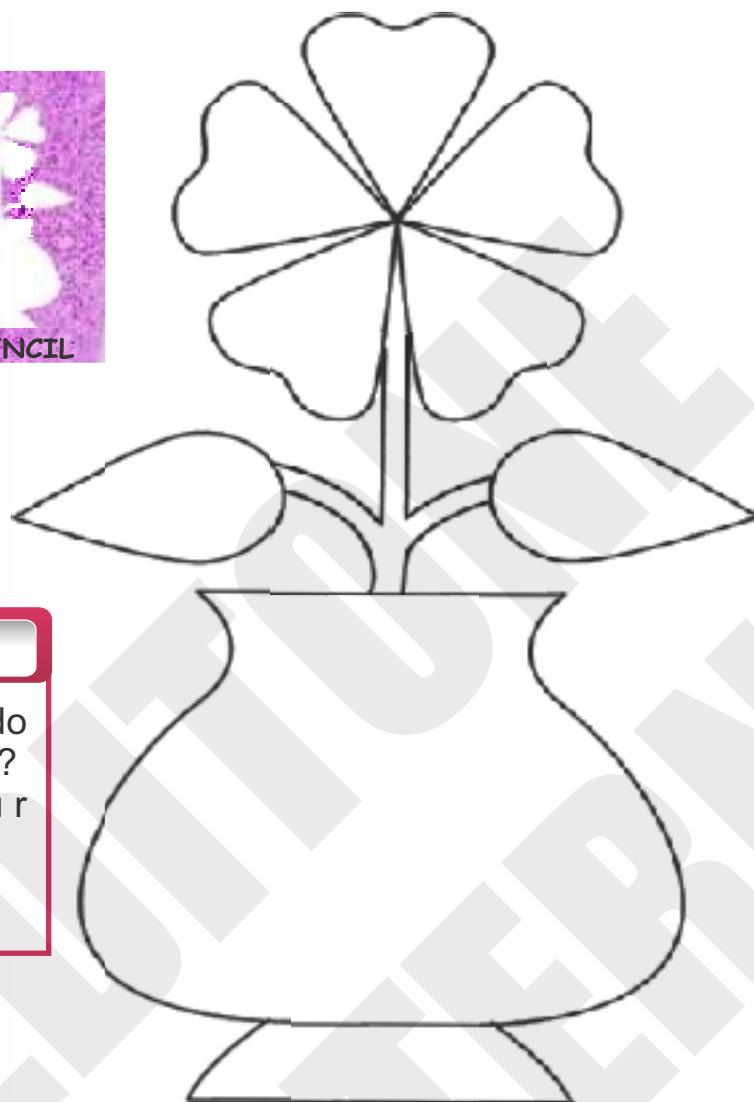
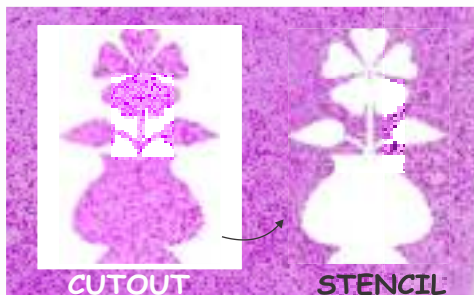

Make this picture with the help of stencil.

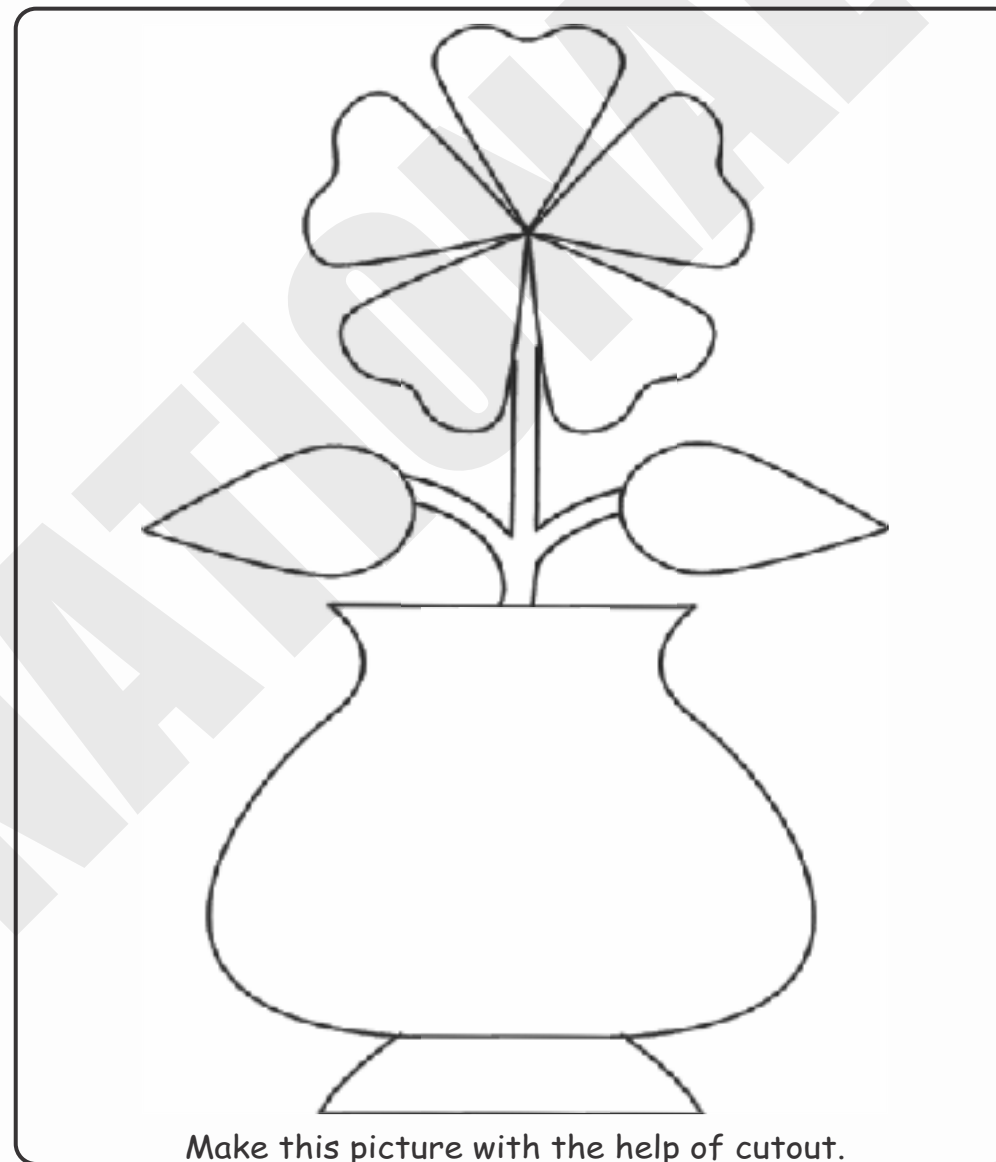

Make this picture with the help of cutout.



### Let Me Answer

- \* How many petals do you see in the flower?
- \* Which is your favourite flower?

Excellent	<input type="checkbox"/>	A	Good	<input type="checkbox"/>	B	Fair	<input type="checkbox"/>	C
-----------	--------------------------	---	------	--------------------------	---	------	--------------------------	---

Teacher's Remark







# Triangular Design

Trace the left half of the design on a tracing paper. Now copy on the right half and colour the design.



## Let Me Answer

- \* How many shapes you can find in this picture?
- \* Which is the national flower of our country?

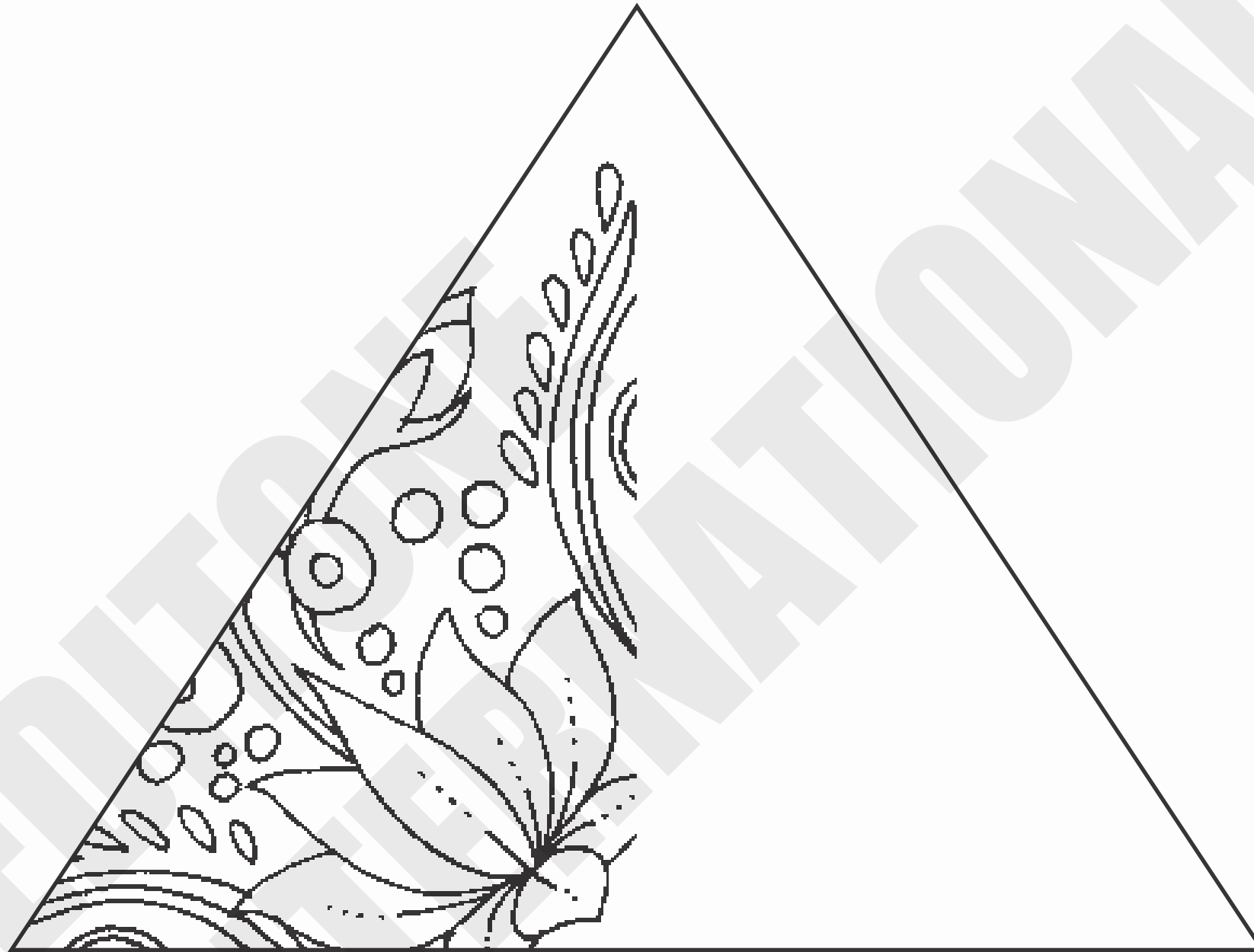

Excellent	<input type="checkbox"/>	A	Good	<input type="checkbox"/>	B	Fair	<input type="checkbox"/>	C
-----------	--------------------------	---	------	--------------------------	---	------	--------------------------	---

Teacher's Remark





# Shaded Landscape

This is the picture of a village landscape.



## Let Me Answer

\* Have you ever travelled on bullock cart?



Shade the given picture according to the picture given on the previous page.  
(Follow strokes to get best results)



### Let Me Answer

\* Have you ever experienced a villager's life?

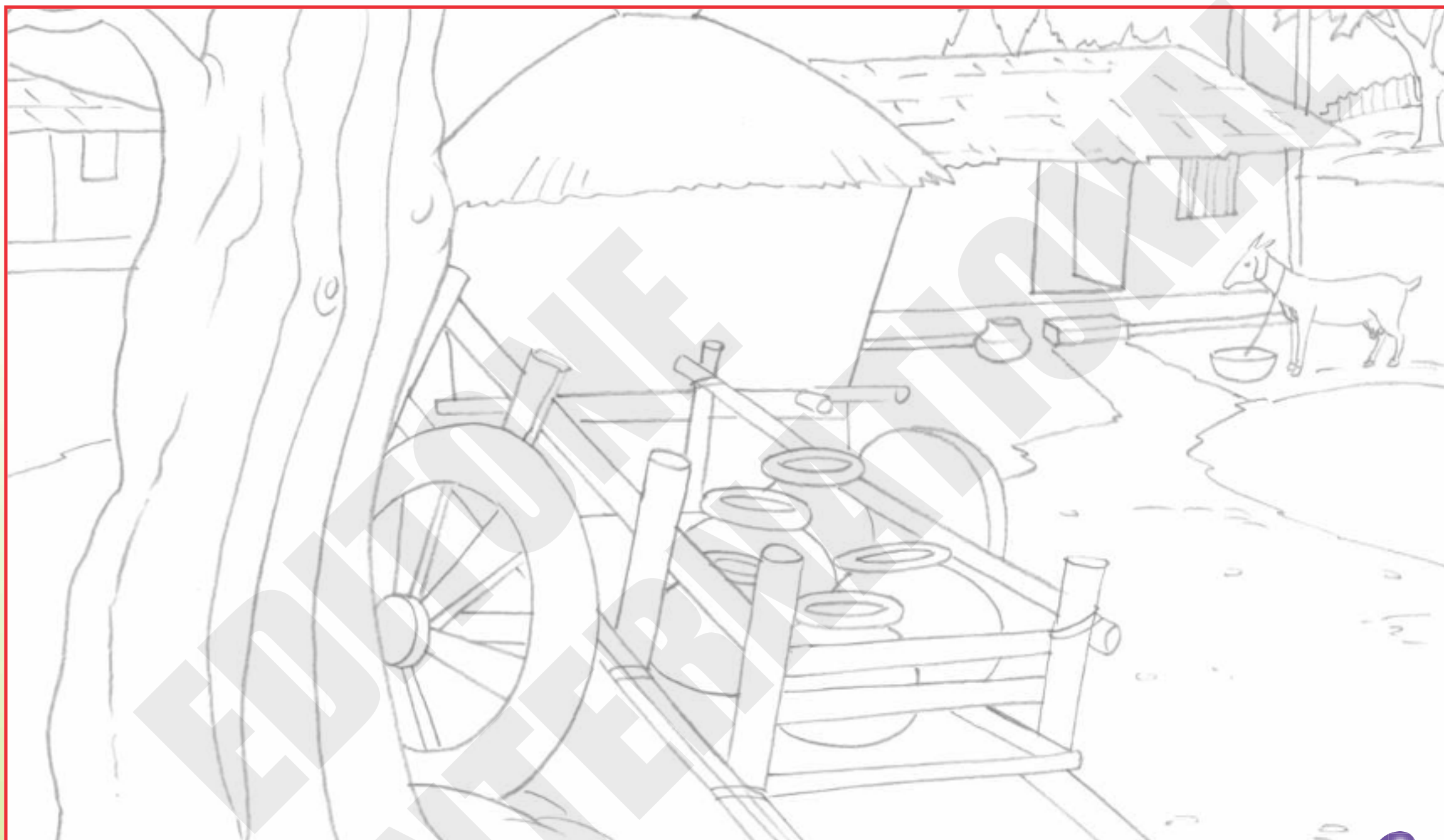

Excellent A  Good B  Fair C

Teacher's Remark





## Oil Pastel Colours

The king of jungle is roaming and enjoying his Kingdom. Colour the picture of this majestic animal with the colours of your choice.



## Thumb Impressions

If you wish you can create figures with your own imagination. Take a colour plate fill it with different water colours. Dip your thumb in it and put thumb impressions on different places using different colours.

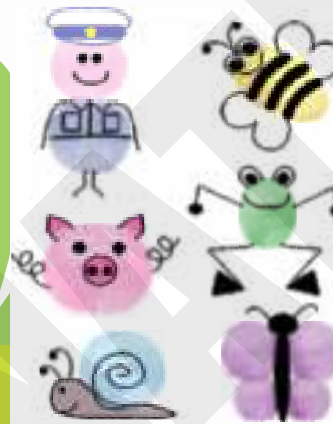

### Let Me Answer

- \* Are lion carnivores or omnivores?
- \* What is the home of lion called?



### Let Me Answer

- \* What is the another name of pig?
- \* Can snails live without a shell?



# Rainbow

Make the rainbow by using small pieces of rice.

Make the rainbow by following the steps given on this page. Colour the clouds with pencil colours.

## Steps

- ➔ Use the outline given on the next page.
- ➔ Take rice and divide it into 7 parts. Using poster colours, colour the rice according to the rainbow colours. Let it dry up.
- ➔ Spread fevicol on the areas you want to colour blue. Sprinkle blue rice on it. Gently pat to set it. Follow same steps for other colours also.
- ➔ No area should be left without rice on it.

**Note :** Let the painting dry up for sometime.



## Let Me Answer

\* How many colours are there in the rainbow?



## Let Me Answer

\* What is the first color of rainbow?

Excellent		A	Good		B	Fair		C
		<input type="checkbox"/>			<input type="checkbox"/>			<input type="checkbox"/>

Teacher's Remark



# ACTIVITY



Fill the picture with different pulses as shown in the reference.

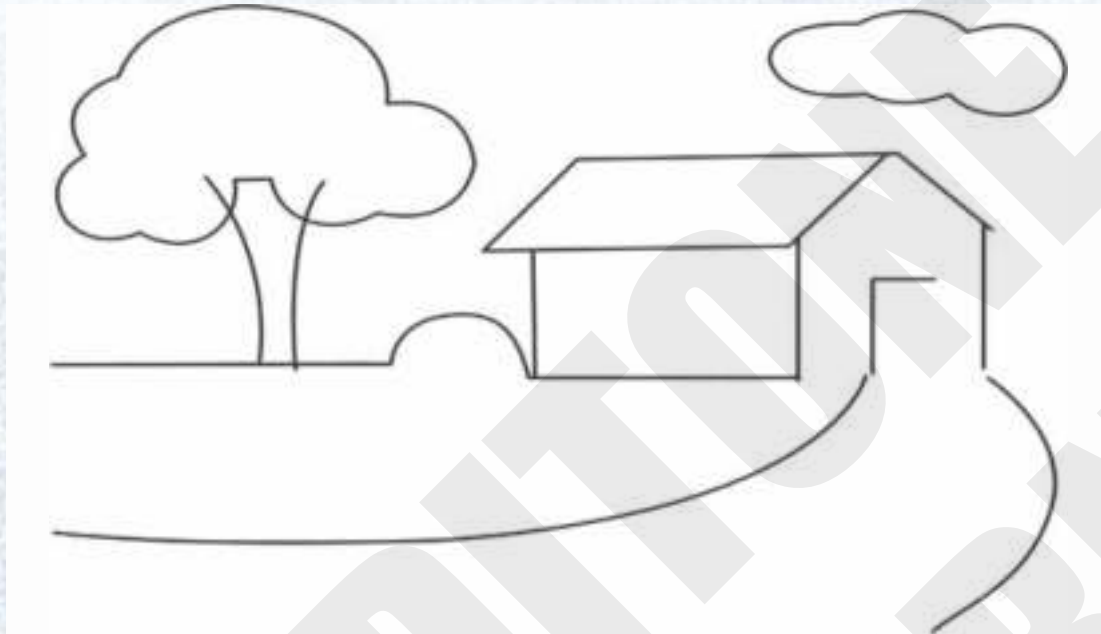

## Let Me Answer

- \* What is the main source of cereals?
- \* What are the three major components of cereals?

# BLOCK PAINTING



Draw the figure given on the blocks as given in the reference. Then colour it.

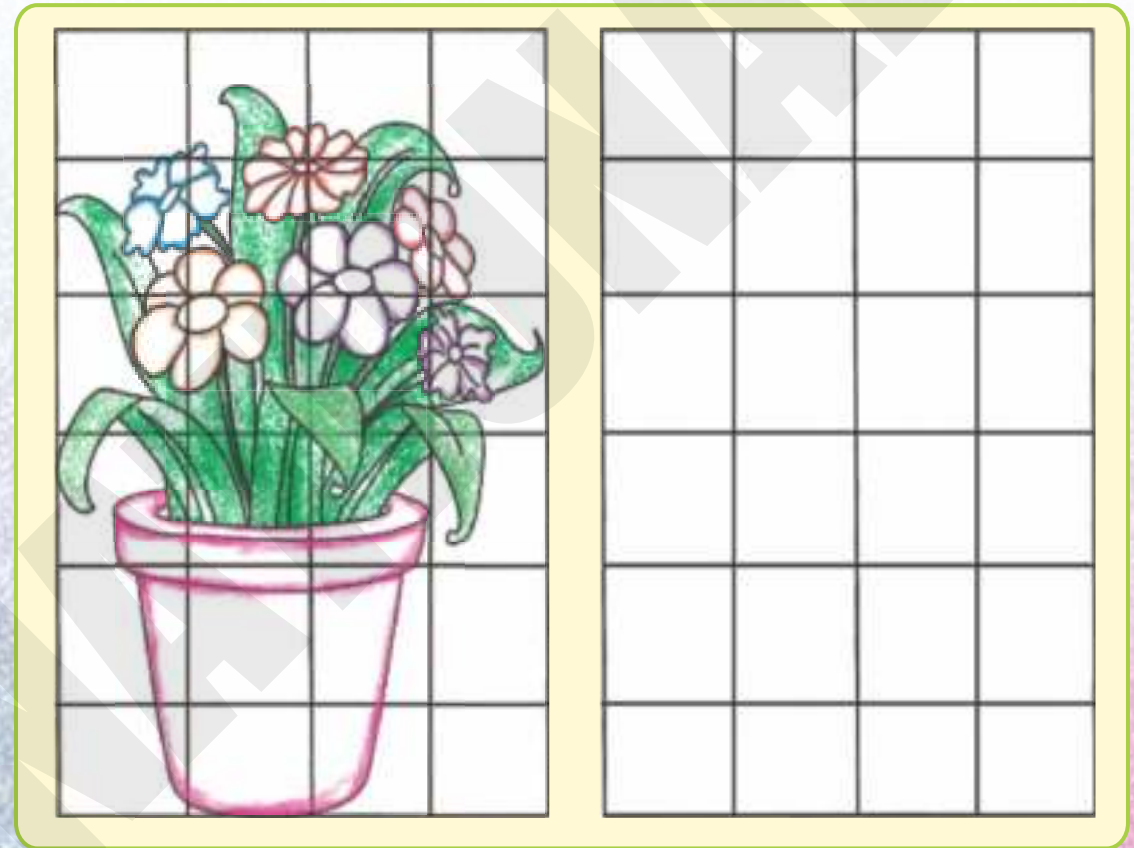

## Let Me Answer

- \* Which type of flower pot is best?
- \* Do plants grow faster in pots?

Excellent		A	Good		B	Fair		C
		<input type="checkbox"/>			<input type="checkbox"/>			<input type="checkbox"/>

Teacher's Remark





# Butterfly With Origami



## Let Me Answer

- \* What is the most common butterfly?
- \* Do butterflies fly at night?



1

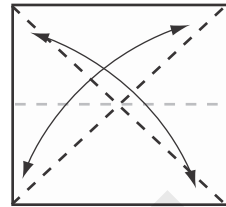

Make creases as shown.

2

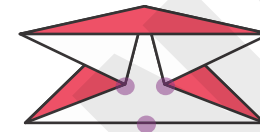

Holding the points, bring them both down to the centre point on the lower line.

3

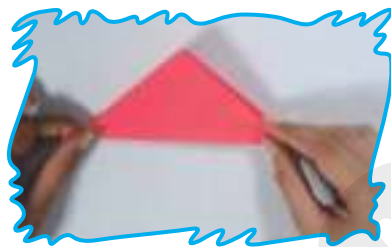
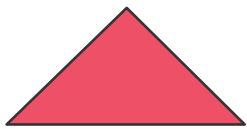

Flatten the model. This is called water bomb base.

4



Fold the left and the right sides upwards to the upper and turn over the model.

5

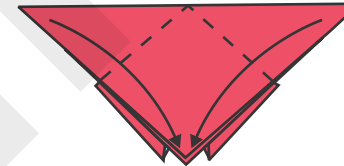

Fold the left and the right sides down to the centre line.

6

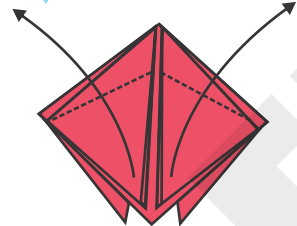

Again fold the upper flaps from the dotted line as given.

7

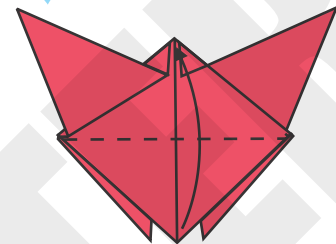

Take the upper flap and fold from the dotted line upwards.

8

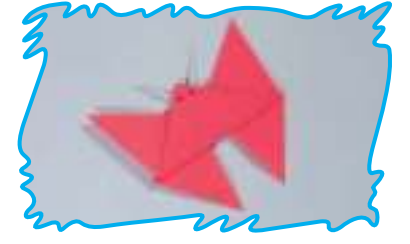
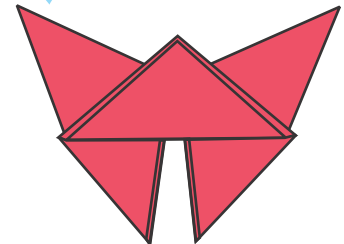

It is completed.

Excellent  A  Good  B  Fair  C  Teacher's Remark





# Brinjal

(Toothbrush Spray Painting)

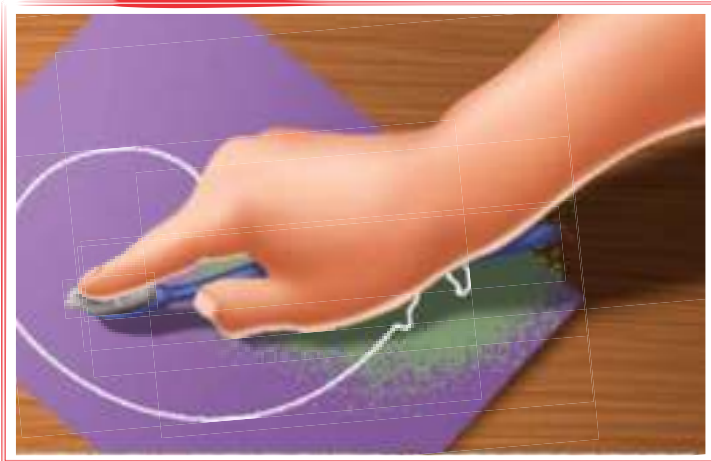

Follow the instructions given below to make a brinjal with toothbrush painting.

- Cut out a stencil of the brinjal given the reference.
- Now take a colour palette. Fill it with violet and green colours.
- Dip the toothbrush into colour.
- Keep the cut stencil in the space provided.
- Spray the colours with your forefingers on and around the stencil by following the colour scheme.
- Pick up the stencil to get the brinjal.



## Let Me Answer

- \* What is other name of brinjal?
- \* Which part of brinjal plant is edible?